



Accraply

A Barry-Wehmiller Packaging Company

High Speed Panel Labeling System

Model 9000P



Features

- Heavy-duty construction utilizes oversized drive components combined with an aluminum and stainless steel base frame for years of dependable service
- Adjustable variable speed conveyor
- Quick “no-tools” adjustments with position indication for fast, repeatable changeover
- Various product infeed systems are available that provide precise product spacing and orientation
- Centrally driven overhead stabilizer belt provides large finishing area and zoned pressure system to compensate for container height variation
- Convenient, centralized pivoting operator interface controls, and touch screen
- Optional multi-positional, line-driven wraparound assembly for cylindrical applications
- Advanced high torque servo driven applicators include ratio-offset and speed-following capability for accurate and reliable application of a wide variety of label materials
- Drop-in-from-the-top label threading with quick release rewind reel core
- Contour following label peelers provide excellent finish on oval containers

Model 9000P High Speed Panel Labeling System

The Accraply Model 9000P is an extremely versatile labeling system designed for the application of front and/or back panel labels on square, rectangular, or oval containers. With the optional multi-panel wiper assemblies, the Model 9000P can also apply two, three or four panel labels.

Rugged construction for demanding, continuous-duty operation; quick, easy changeover capability from one product to another; and proven technology make this system an exceptional value.

Options

- Additional label applicators
- Hot stamp printer or various other printers
- 9" wide web label capacity
- Multi-panel label wipers
- Various width wrap assemblies
- Clear film label sensors
- Outfeed product backlog sensor
- Conveyor extensions
- Free standing large capacity label unwinds
- Inspection options

Application Rate	Up to 3000" per minute
Production Rates	Up to 1000 per minute depending on product and label size
Electrical Requirements	220VAC, Single Phase, 60 Hz, 20 Amp Service
Air Requirements	80 PSI
Product Conveyor	4.5" wide flush sided flat ground top plate
Product Capacity	Maximum Length: 12" Maximum Width: 8" Maximum Height: 12.5" Minimum Length: 1" Minimum Width: .75" Minimum Height: 1.75"
Label Capacity	16" Rolls, 3" Cores Maximum Length: 12" Maximum Height: 6" Minimum Length: .375" Minimum Height: .375"

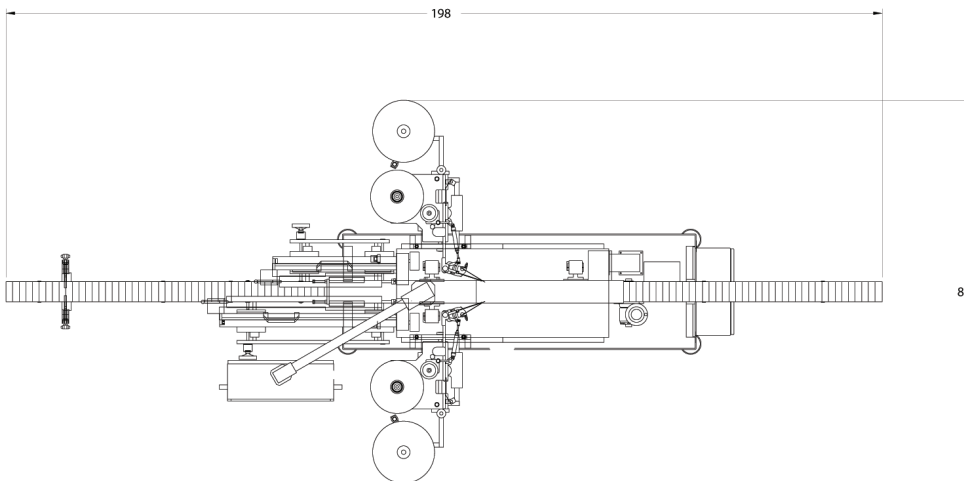

Accraply

Trine

Stanford

Graham

Sleevit

Harland

BW Packaging Systems represents the collective capabilities of Barry-Wehmiller packaging companies including, Accraply, BW Flexible Systems, BW Integrated Systems, Pneumatic Scale Angelus and Synerlink. Through their diverse capabilities, these companies can collectively provide everything from a single piece of equipment to fully integrated packaging systems for a wide range of industries, including: food and beverage, personal care, container manufacturing, pharmaceutical and medical devices, household products, paper products and textiles, industrial and automotive, and converting, printing and publishing. For more information, go to BWPackagingSystems.com

